

MODEL : TN-3000-224 OUTPUT:230V/50Hz

AC OUTPUT FUNCTION TEST

NO	TEST ITEM	SPECICATION	TEST CONDITION	RESULT	VERDICT
1	RATED POWER (TYP)	3000W	I/P: 24VDC Ta:25°C	<u>3000 W</u>	P
2	WAVEFORM	True sine wave (THD<3%)	I/P: 26VDC O/P: FULL LOAD Ta:25°C	FULL LOAD: <u>1.52 %</u>	P
3	FREQUENCY	50HZ ± 0.1HZ	I/P: 24VDC O/P: FULL LOAD Ta:25°C	FULL LOAD: <u>50.02</u> HZ	P
4	AC REGULATION (TYP)	±3%	I/P: 24VDC O/P: FULL LOAD/NO LOAD Ta:25°C	0.7%	P
5	MAXIMUM OUTPUT POWER	(1)3450W/180sec. (2)4500w/10sec (3)SURGE POWER 6000W FOR 30CYCLE Vdc ≤ 27V SURGE POWER 6000W FOR 5 CYCLE FOR Vbat>27Vdc	I/P: 24VDC O/P: TESTING LOAD Ta:25°C ※LED DISPLAY	(1) <u>3440W</u> /180_SEC (2) <u>4389W</u> /10_SEC (3) <u>5659W</u> / 38 CYCLE FOR ≤ 27Vdc <u>6394W</u> / 15 CYCLE FOR >27VDC	P
6	SAVING MODE TO NORMAL	Po>7W~15W	I/P: 24VDC O/P:NO LOAD Ta:25°C ※LED DISPLAY	<u>11 W</u>	P
7	NORMAL TO SAVING MODE(TYP)	Po ≤ 5W	I/P: 24VDC O/P:NO LOAD Ta:25°C ※LED DISPLAY	<u>5 W</u>	P
8	TRANSFER TIME(TYP)	t <10 mS inverter↔by pass	I/P: 24VDC O/P:FULL LOAD Ta:25°C	INVERTER→BY PASS <u>9.2</u> ms BY PASS→INVERTER <u>10</u> ms	P

DC INPUT FUNCTION TEST

NO	TEST ITEM	SPECICATION	TEST CONDITION	RESULT	VERDICT
1	DC CURRENT (TYP)	150A	I/P: 24VDC O/P:FULL LOAD Ta:25°C	<u>136.2 A</u>	P
2	NO LOAD DISSIPATION(TYP)	≤ 10W @standby saving mode	I/P: 24VDC O/P:NO LOAD Ta:25°C	<u>9.6 W/24VDC</u>	P
3	OFF MODE DRAW CURRENT	≤ 1mA	I/P: 24VDC SW OFF O/P:NO LOAD Ta:25°C	<u>0.9</u> /24VDC	P

4	VOLTAGE RANGE (TYP)	21±1VDC~30±1VDC	I/P: TESTING O/P:NO LOAD/FULL LOAD Ta:25°C	<u>20.8</u> VDC~ <u>29.5</u> VDC/NO LOAD <u>21.1</u> VDC~ <u>29.5</u> VDC/FULL LOAD	P
5	EFFICIENCY(TYP)	91%	I/P: 26VDC O/P: Po=2100W Ta:25°C	92.1%	P

BATTERY INPUT PROTECTION FUNCTION TEST

NO	TEST ITEM	SPECICATION	TEST CONDITION	RESULT	VERDICT
1	BAT LOW ALARM (INVERTER MODE)	21.5V ~ 23.5VDC	I/P: TESTING O/P:FULL LOAD Ta:25°C ※LED DISPLAY	<u>22.36</u> V	P
2	BAT LOW SHUT DOWN	20V ~ 22VDC	I/P: TESTING O/P: FULL LOAD Ta:25°C ※LED DISPLAY	<u>21.1</u> V Shut down Recovery	P
3	BAT. RECOVERY VOLTAGE	27.4DC~29.4VDC	I/P: TESTING O/P:FULL LOAD Ta:25°C	28.4V	P
4	TRANSFER TO AC BY PASS	21VDC ~23VDC	I/P: TESTING O/P: FULL LOAD Ta:25°C	22V	P
5	BY PASS TRANSFER TO INVERTER	27.5VDC~29.5VDC	I/P: TESTING O/P: FULL LOAD Ta:25°C	28.04V	P
6	OVER VOLTAGE	29VDC~31VDC	I/P: TESTING O/P:FULL LOAD Ta:25°C	29.5V	P

AC OUTPUT PROTECTION FUNCTION TEST

NO	TEST ITEM	SPECICATION	TEST CONDITION	RESULT	VERDICT
1	OVER TEMPERATURE	SPEC : TSW1 : 75 ± 5°C O.T.P. NO DAMAGE	I/P: 24VDC O/P: FULL LOAD SET:SAVING MODE Ta:25°C ※LED DISPLAY	O.T.P. Active Shut down o/p voltage Re-power on to recover	P
2	SHORT PROTECTION	SHORT EVERY OUTPUT NO DAMAGE	I/P:29.5VDC O/P: FULL LOAD TEST: 3 TIMES Ta:25°C ※LED DISPLAY	NO DAMAGE Shut down o/p voltage Re-power on to recover	P

3	OVER LOAD (INVERTER)	105%~115%LOAD 180sec 115%~150%LOAD10 Sec Shutdown Re-power ON	I/P: 24VDC O/P: TESTING Ta:25°C ※LED DISPLAY	24VDC: <u>111</u> % <u>180</u> sec <u>140</u> % <u>10</u> sec Shut down Re-power ON	P
---	----------------------	---	---	---	---

FAN CONTROL FUNCTION TEST

NO	TEST ITEM	SPECICATION	TEST CONDITION	RESULT	VERDICT
1	FAN SPEED CONTROL	-----	I/P: 24VDC O/P: FULL LOAD Ta:25°C	Fan Voltage= 12.56 V	P
2	FAN LOCK	Shut down Re-power ON	I/P: 24VDC O/P: FULL LOAD Ta:25°C ※LED DISPLAY	Shut down Re-power ON	P

AC CHARGER

NO	TEST ITEM	SPECICATION	TEST CONDITION	RESULT	VERDICT
1	CHARGE CURRENT	12A±1.5A	I/P: 230VAC O/P:CV MODE=24V ACLOAD:FULL LOAD Ta:25°C	12.86A	P
2	CHARGE VOLTAGE	27.5VDC~29.5 VDC	I/P: 230VAC O/P:NO LOAD ACLOAD:NO LOAD Ta:25°C	28.1V	P

SOLAR CHARGER

NO	TEST ITEM	SPECICATION	TEST CONDITION	RESULT	VERDICT
1	MAX O/PEN CIRCUIT VOLTAGE	45V /30A	I/P: DC SOURCE O/P:BATTERY Ta:25°C	45 V 30 A	P
2	CHARGE VOLTAGE	27.5VDC~29.5VDC	I/P: DC SOURCE O/P:BATTERY Ta:25°C	28.06V	P

APPLICATION TEST

NO	TEST ITEM	SPECICATION	TEST CONDITION	RESULT	VERDICT
1	INDUCTION MOTOR	1HP	I/P: BATTERYVOLTAGE O/P:1HP Ta:25°C	INVERTER TURN ON/OFF :OK INDUCTION MOTOR ON/OFF:OK	P
2	SWITCHING POWER SUPPLY	RSP-1500-48*2PIC(Pin=3000W)	I/P:BATTERYVOLTAGE(190H52) O/P: RSP-1500-48*2PIC (Pin=3000W) Ta:25°C	INVERTER TURN ON/OFF :OK INDUCTION MOTOR ON/OFF:OK	P

Load indicator test

Load indicator test							
LED INDICATOR	LOAD RANGE	RESULT	VERDICT	LED INDICATOR	LOAD RANGE	RESULT	VERDICT
	0W ~ 750W±150W	<763W	P		1500W±150W ~ 2250W±150W	1490W~ 2210W	P
	750W±150W ~ 1500W±150W	763W~ 1490W	P		2250W±150W ~ 3000W	>2210W~ 3000W	P

Battery capacity indicator test

Battery capacity indicator test							
Inverter mode				By-pass mode			
LED INDICATOR	VOLTAGE RANGE	RESULT	VERDICT	LED INDICATOR	VOLTAGE RANGE	RESULT	VERDICT
	21.4V ~ 23.4V 2 LEDs→1 LED (22.4V)	22.5V	P		<24V (25V)	<25V	P
	22.6V ~ 24.6V 3 LEDs→2 LEDs (23.6V)	23.6V	P		24.2V ~26.2V 1 LED→2 LEDs (25.2V)	25.5V	P
	22.8V ~24.8V 4 LEDs→3 LEDs (23.8V)	23.6V	P		25.4V ~27.4V 2 LEDs →3 LED (26.4V)	26.7V	P
	> 25.4V (24.4V)	24.3V	P		26.8V ~29.8V 3 LEDs →4 LEDs (27.8V)	28.2V	P

Battery low alarm test

Battery low alarm test					
O/PERATING MODE	VOLTAGE RANGE	LED INDICATOR	VOLTAGE RANGE	LED	VERDICT
Inverter mode	21.5V ~ 23.5V	Bat Low Buzzer sounds	22.36V	OK	P
By-pass mode & Saving mode	24.2V ~26.2V	Bat Low	25.08V	OK	P

Solar charger test

Solar charger test					
STATUS	VOLTAGE RANGE	LED INDICATOR	NOTE	VOLTAGE RANGE	VERDICT
ON	25.4V ~ 27.4V		Solar charging current > 3.5A ; LED ON Solar charging current < 1A ; LED OFF	26.07V	P
OFF	27.5V ~29.5V		LED OFF	28.06V	P

Saving mode test

NOTE : Both of load & battery indictors should be off under saving mode

Saving mode test				
O/PERATING MODE	POWER LEVEL FOR TRANSITION	LED INDICATOR	P _o	VERDICT
Saving mode → Normal mode	7W<P _o <15W		11W	P
Normal mode → Saving mode	P _o < 10W		6W	P

POWER ON AND MODE SETTING CODES:

1.O/Peration Mode Selection

O/PERATION MODE	LED INDICATORS	VERDICT
Energy Saving mode	RED ● YELLOW ★ GREEN ★	P
UPS mode	RED ○ YELLOW ★ GREEN ★	P

↓After pushing button 3 seconds and beeping

2.Voltage And Frequency Mode Selection

	100V (200V)	110V (220V)	115V (230V)	240V (240V)
50Hz	RED ● YELLOW ○ GREEN ○	RED ● YELLOW ○ GREEN ●	RED ● YELLOW ● GREEN ○	RED ● YELLOW ● GREEN ●
VERDICT	P	P	P	P

60Hz	RED ★ YELLOW ○ GREEN ○	RED ★ YELLOW ○ GREEN ●	RED ★ YELLOW ● GREEN ○	RED ★ YELLOW ● GREEN ●
VERDICT	P	P	P	P

↓After pushing button 3 seconds and beeping

3.Saving Mode Selection

Saving mode	LED INDICATOR	VERDICT
ENABLED	RED ★ YELLOW ★ GREEN ●	P
DISABLED	RED ★ YELLOW ★ GREEN ○	P

ERROR CODE LED INDICATOR

Error code								
LED INDICATOR	FAILURE MESSAGE	VERDICT	LED INDICATOR	FAILURE MESSAGE	VERDICT	LED INDICATOR	FAILURE MESSAGE	VERDICT
	105% OLP	P		115% OLP	P		150% OLP	P
	OTP	P		Inverter OVP Or Inverter UVP	P		AC output fail (O/P short)	P
	Battery low shutdown	P		Battery bad or Battery notch	P		FAN -LOCK	P
	Remote-off	P						

VOLTAGE RANGE OF AC UTILITY FOR O/PERATION MODE TRANSITION :

AC input high / low line limit				
AC MAINS	VOLTAGE LIMIT	VOLTAGE RANGE	RESULT	VERDICT
230V	High limit (To INV mode)	Vac > 268±8V	268V	P
	Recovery to high (To AC mode)	Vac < 258±8V	256V	P
	Low limit (To INV mode)	Vac < 188±8V	189V	P
	Recovery to low (To AC mode)	Vac > 195±8V	197V	P

UPS MODE VERIFICATION

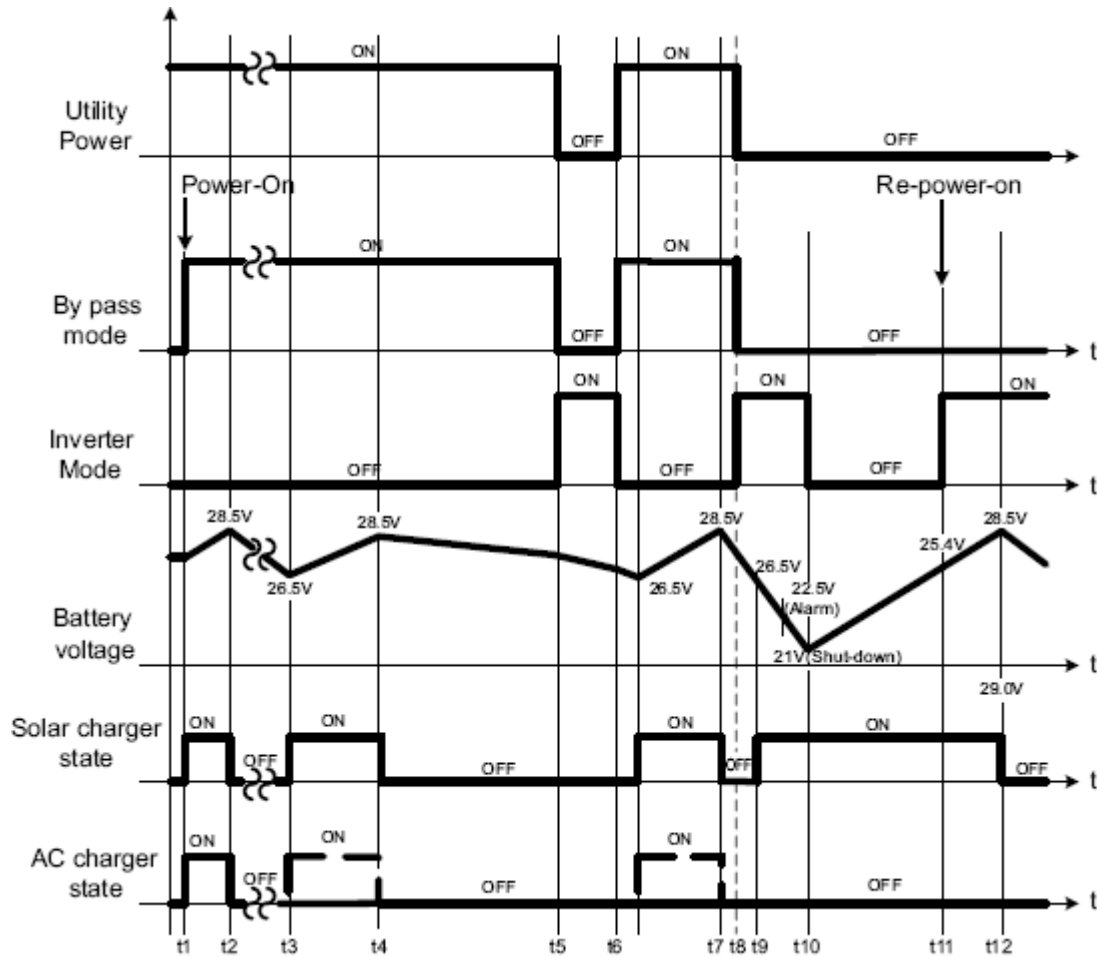

TIME SEQUENCE	TEST CONDITIONS	LED INDICATOR STATUS		VERDICT
t1	1、AC utility in → 110V/220V 2、Battery voltage → 12V/24V/48V 3、Solar charging current → 3.5A	1、AC IN 2、AC CHARGER 3、SOLAR CHARGER 4、INVERTER 5、BY PASS	1、 <input checked="" type="checkbox"/> 2、 <input checked="" type="checkbox"/> 3、 <input checked="" type="checkbox"/> 4、 <input type="checkbox"/> 5、 <input checked="" type="checkbox"/>	P
t2	1、AC utility in → 110V/220V 2、Battery voltage → 14.5V/29V/58V 3、Solar charging current → 3.5A	1、AC IN 2、AC CHARGER 3、SOLAR CHARGER 4、INVERTER 5、BY PASS	1、 <input checked="" type="checkbox"/> 2、 <input type="checkbox"/> 3、 <input type="checkbox"/> 4、 <input type="checkbox"/> 5、 <input checked="" type="checkbox"/>	P
t3	1、AC utility in → 110V/220V 2、Battery voltage →	1、AC IN 2、AC CHARGER	1、 <input checked="" type="checkbox"/> 2、 <input type="checkbox"/>	P

	13V/26V/52V 3、Solar charging current → 3.5A	3、SOLAR CHARGER 4、INVERTER 5、BY PASS	3、 <input checked="" type="checkbox"/> 4、 <input type="checkbox"/> 5、 <input checked="" type="checkbox"/>	
t3'	1、AC utility in → 110V/220V 2、Battery voltage → 13V/26V/52V 3、Solar charging current → 0A	1、AC IN 2、AC CHARGER 3、SOLAR CHARGER 4、INVERTER 5、BY PASS	1、 <input checked="" type="checkbox"/> 2、 <input checked="" type="checkbox"/> 3、 <input type="checkbox"/> 4、 <input type="checkbox"/> 5、 <input checked="" type="checkbox"/>	P
t5	1、AC utility disconnected 2、Battery voltage → 14.5V/29V/58V 3、Solar charging current → 3.5A	1、AC IN 2、AC CHARGER 3、SOLAR CHARGER 4、INVERTER 5、BY PASS	1、 <input type="checkbox"/> 2、 <input type="checkbox"/> 3、 <input type="checkbox"/> 4、 <input checked="" type="checkbox"/> 5、 <input type="checkbox"/>	P
t6	1、AC utility in → 110V/220V 2、Battery voltage → 14.5V/29V/58V 3、Solar charging current → 3.5A	1、AC IN 2、AC CHARGER 3、SOLAR CHARGER 4、INVERTER 5、BY PASS	1、 <input checked="" type="checkbox"/> 2、 <input type="checkbox"/> 3、 <input type="checkbox"/> 4、 <input type="checkbox"/> 5、 <input checked="" type="checkbox"/>	P
t9	1、AC utility disconnected 2、Battery voltage → 13V/26V/52V 3、Solar charging current → 3.5A	1、AC IN 2、AC CHARGER 3、SOLAR CHARGER 4、INVERTER 5、BY PASS	1、 <input type="checkbox"/> 2、 <input type="checkbox"/> 3、 <input checked="" type="checkbox"/> 4、 <input checked="" type="checkbox"/> 5、 <input type="checkbox"/>	P
t10	1、AC utility disconnected 2、Battery voltage → 10.5V/21V/42V 3、Solar charging current → 3.5A	1、AC IN 2、AC CHARGER 3、SOLAR CHARGER 4、INVERTER 5、BY PASS ⊙Inverter shut down	1、 <input type="checkbox"/> 2、 <input type="checkbox"/> 3、 <input checked="" type="checkbox"/> 4、 <input type="checkbox"/> 5、 <input type="checkbox"/> error0111	P
t11	1、AC utility disconnected 2、Battery voltage → 13V/26V/52V 3、Solar charging current → 3.5A	1、AC IN 2、AC CHARGER 3、SOLAR CHARGER 4、INVERTER 5、BY PASS ⊙Inverter resumes normal O/Peration	1、 <input type="checkbox"/> 2、 <input type="checkbox"/> 3、 <input checked="" type="checkbox"/> 4、 <input checked="" type="checkbox"/> 5、 <input type="checkbox"/>	P

ESM MODE VERIFICATION

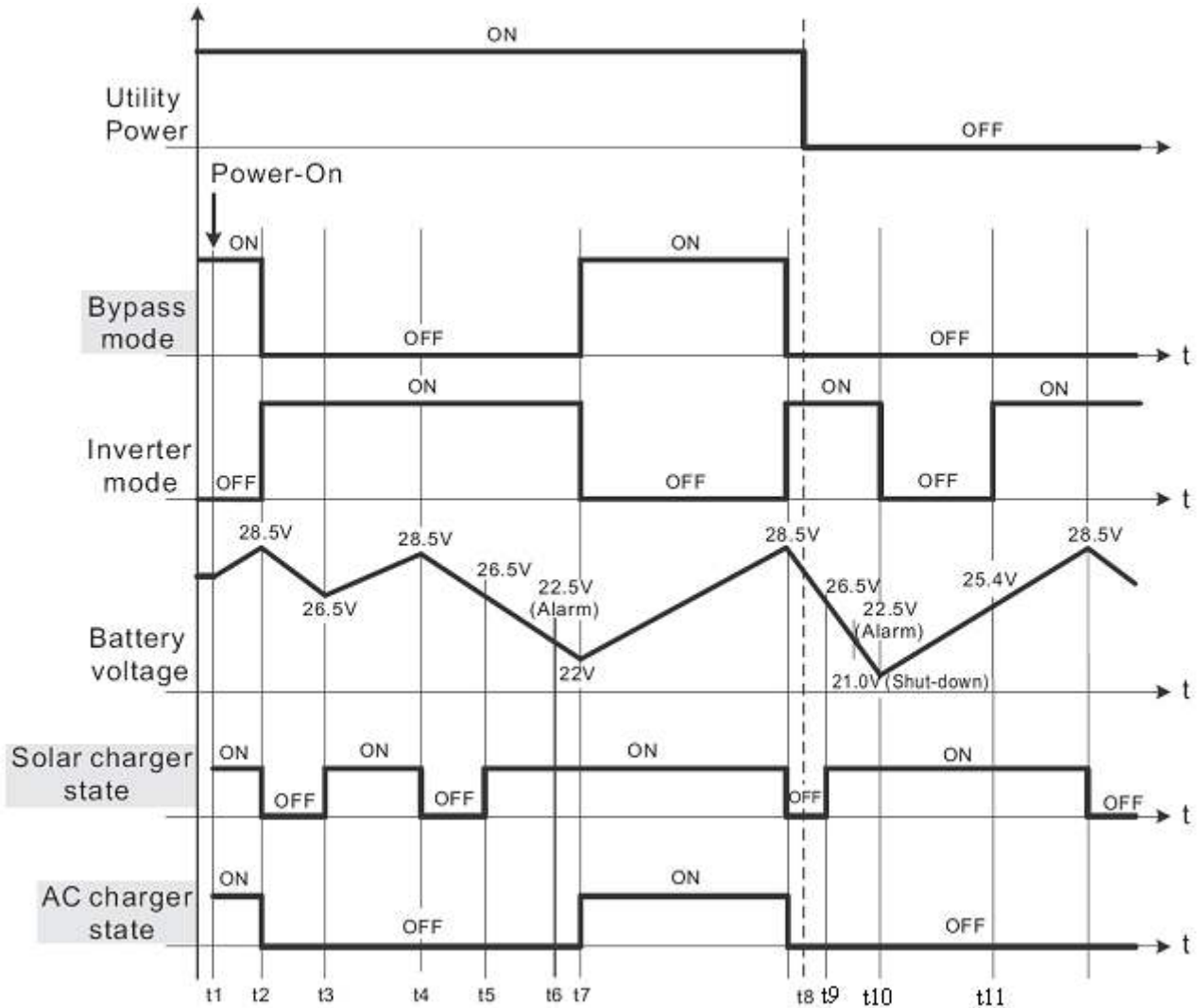

TIME SEQUENCE	TEST CONDITIONS	LED INDICATOR STATUS		VERDICT
t1	1、AC utility in → 110V/220V 2、Battery voltage → 12V/24V/48V 3、Solar charging current → 3.5A	1、AC IN 2、AC CHARGER 3、SOLAR CHARGER 4、INVERTER 5、BY PASS	1、 <input checked="" type="checkbox"/> 2、 <input checked="" type="checkbox"/> 3、 <input checked="" type="checkbox"/> 4、 <input type="checkbox"/> 5、 <input checked="" type="checkbox"/>	P
t2	1、AC utility in → 110V/220V 2、Battery voltage → 14.5V/29V/58V 3、Solar charging current →	1、AC IN 2、AC CHARGER 3、SOLAR CHARGER 4、INVERTER	1、 <input checked="" type="checkbox"/> 2、 <input type="checkbox"/> 3、 <input type="checkbox"/> 4、 <input checked="" type="checkbox"/>	P

	3.5A	5、BY PASS	5、 <input type="checkbox"/>	
t3	1、AC utility in → 110V/220V 2、Battery voltage → 13V/26V/52V 3、Solar charging current → 3.5A	1、AC IN 2、AC CHARGER 3、SOLAR CHARGER 4、INVERTER 5、BY PASS	1、 <input checked="" type="checkbox"/> 2、 <input type="checkbox"/> 3、 <input checked="" type="checkbox"/> 4、 <input checked="" type="checkbox"/> 5、 <input type="checkbox"/>	P
t4	1、AC utility in → 110V/220V 2、Battery voltage → 14.5V/29V/58V 3、Solar charging current → 0A	1、AC IN 2、AC CHARGER 3、SOLAR CHARGER 4、INVERTER 5、BY PASS	1、 <input checked="" type="checkbox"/> 2、 <input type="checkbox"/> 3、 <input type="checkbox"/> 4、 <input checked="" type="checkbox"/> 5、 <input type="checkbox"/>	P
t7	1、AC utility in → 110V/220V 2、Battery voltage → 11V/22V/44V 3、Solar charging current → 3.5A	1、AC IN 2、AC CHARGER 3、SOLAR CHARGER 4、INVERTER 5、BY PASS	1、 <input checked="" type="checkbox"/> 2、 <input type="checkbox"/> 3、 <input checked="" type="checkbox"/> 4、 <input type="checkbox"/> 5、 <input checked="" type="checkbox"/>	P
t8	1、AC utility disconnected 2、Battery voltage → 14.5V/29V/58V 3、Solar charging current → 3.5A	1、AC IN 2、AC CHARGER 3、SOLAR CHARGER 4、INVERTER 5、BY PASS	1、 <input type="checkbox"/> 2、 <input type="checkbox"/> 3、 <input type="checkbox"/> 4、 <input checked="" type="checkbox"/> 5、 <input type="checkbox"/>	P
t9	1、AC utility disconnected 2、Battery voltage → 12V/24V/48V 3、Solar charging current → 3.5A	1、AC IN 2、AC CHARGER 3、SOLAR CHARGER 4、INVERTER 5、BY PASS	1、 <input type="checkbox"/> 2、 <input type="checkbox"/> 3、 <input checked="" type="checkbox"/> 4、 <input checked="" type="checkbox"/> 5、 <input type="checkbox"/>	P
t10	1、AC utility disconnected 2、Battery voltage → 10.5V/21V/42V 3、Solar charging current → 3.5A	1、AC IN 2、AC CHARGER 3、SOLAR CHARGER 4、INVERTER 5、BY PASS ⊙Inverter shuts down.	1、 <input type="checkbox"/> 2、 <input type="checkbox"/> 3、 <input checked="" type="checkbox"/> 4、 <input type="checkbox"/> 5、 <input type="checkbox"/> error0111	P
t11	1、AC utility disconnected 2、Battery voltage → 13V/26V/52V 3、Solar charging current → 3.5A	1、AC IN 2、AC CHARGER 3、SOLAR CHARGER 4、INVERTER 5、BY PASS ⊙Inverter re-powers on to recover	1、 <input type="checkbox"/> 2、 <input type="checkbox"/> 3、 <input checked="" type="checkbox"/> 4、 <input checked="" type="checkbox"/> 5、 <input type="checkbox"/>	P

COMPONENT STRESS TEST

NO	TEST ITEM	SPECICATION	TEST CONDITION	RESULT	VERDICT
1	DC TO DC Power Transistor (D to S) or (C to E) Peak Voltage	Q 310 Rated IRFB4321PbF 83A/150V	I/P:29VDC O/P: (1)Full Load Turn On (2) Output Short (3)Full load continue Ta:25°C	(1) 108 V (2) 129 V (3) 80 V	P
2	DC TO DC Diode Peak Voltage	D 400 Rated YG975C6R 20A/600V	I/P:29VDC O/P: (1)Full Load Turn On (2) Output Short (3)Full load continue Ta:25°C	(1) 444 V (2) 444 V (3) 444 V	P
3	DC BUS Capacitor Voltage	C403 Rated 330u/450V 105°C 25*50 MXG	I/P:29VDC O/P: (1)Full Load Turn SW On /Off (2) Min load Turn SW On /Off (3)Full Load /Min load Change Ta:25°C	(1) 436 V (2) 436 V (3) 436 V	P
4	DC TO AC Power Transistor (D to S) or (C to E) Peak Voltage	Q 51 Rated IRGP50B60PD1pbF 50A/600V	I/P:29VDC O/P: (1)Full Load Turn On (2) Output Short (3)Full load continue Ta:25°C	(1) 456 V (2) 570 V (3) 456 V	P
5	DC TO FAN Power Transistor (D to S) or (C to E) Peak Voltage	Q 100 Rated IRFB52N15DPbF 51A/150V	I/P:29VDC O/P: (1)Full Load Turn On (2) Output Short (3)Full load continue Ta:25°C	(1) 111 V (2) 120 V (3) 88 V	P
6	DCTO FAN Diode Peak Voltage	D 200 Rated MBR20H100CT 20A/100V	I/P:29VDC O/P: (1)Full Load Turn On (2) Output Short (3)Full load continue Ta:25°C	(1) 81 V (2) 61.8 V (3) 78 V	P
7	FAN TO CPU Power Transistor (D to S) or (C to E) Peak Voltage	Q601 Rated STP75NF75 80A/75V	I/P:29VDC O/P: (1)Full Load Turn On (2) Output Short (3)Full load continue Ta:25°C	(1) 44.8 V (2) 33.4 V (3) 44.8 V	P
8	FAN TO CPU Diode Peak Voltage	D 630 Rated 21DQ10 2A/100V	I/P:29VDC O/P: (1)Full Load Turn On (2) Output Short (3)Full load continue Ta:25°C	(1) 62 V (2) 55.3 V (3) 62 V	P
9	AC CHARGE Power Transistor (D to S) or (C to E) Peak Voltage	Q701 2SK3878:900V9A	I/P:110 VAC O/P: (1)Full Load Turn On (2)Full load continue Ta:25°C	(1) 800 V (2) 800 V	P
10	AC CHARGE OUPUTDIODE Peak Voltage	D800 SF20LC30 20A/300V	I/P:110 VAC O/P: (1)Full Load Turn On (2)Full load continue Ta:25°C	(1) 128 V (2) 127 V	P
11	SOLAR CHARGE Power Transistor (D to S) or (C to E) Peak Voltage	Q850 STP75NF75:75V/80A	I/P:45 VDC O/P: (1)Full Load Turn On (2)Full load continue Ta:25°C	(1) 45.4 V (2) 45 V	P

Reliability Test report

NO	TEST ITEM	SPECIFICATION	TEST CONDITION	RESULT	VERDICT																																																																																																																																																																																																				
1	TEMPERATURE RISE TEST	MODEL : TN-3000-212			P																																																																																																																																																																																																				
		1. ROOM AMBIENT BURN-IN : 2 HRS																																																																																																																																																																																																							
		I/P : 12VDC O/P : FULL LOAD Ta= 32.9 °C																																																																																																																																																																																																							
		2. HIGH AMBIENT BURN-IN : 2 HRS																																																																																																																																																																																																							
		I/P : 12VDC O/P : FULL LOAD Ta= 35.5 °C																																																																																																																																																																																																							
				<table border="1"> <thead> <tr> <th>NO</th> <th>Position</th> <th>P/N</th> <th>ROOM AMBIENT Ta= 32.9°C</th> <th>HIGH AMBIENT Ta= 35.5 °C</th> </tr> </thead> <tbody> <tr><td>6</td><td>C333</td><td>2200u/16V L10Kh 105°C YXG</td><td>65.8°C</td><td>71.3°C</td></tr> <tr><td>7</td><td>L330</td><td>TF1966-R1</td><td>75.4°C</td><td>84.7°C</td></tr> <tr><td>8</td><td>C337</td><td>755/250V 5% P=32.5 MPE</td><td>71.8°C</td><td>76.8°C</td></tr> <tr><td>9</td><td>T330 COIL</td><td>TF2007-R2</td><td>91.0°C</td><td>97.9°C</td></tr> <tr><td>10</td><td>T330 CORE</td><td>TF2007-R2</td><td>77.3°C</td><td>84.2°C</td></tr> <tr><td>11</td><td>Q337</td><td>FET IXT160N075T 160A/75V TO220</td><td>98.9°C</td><td>107.4°C</td></tr> <tr><td>12</td><td>Q333</td><td>FET IXT160N075T 160A/75V TO220</td><td>83.8°C</td><td>92.4°C</td></tr> <tr><td>13</td><td>Q350</td><td>FET IXT160N075T 160A/75V TO220</td><td>75.7°C</td><td>84.1°C</td></tr> <tr><td>14</td><td>D330</td><td>HER203 2A/200V</td><td>90.3°C</td><td>98.6°C</td></tr> <tr><td>15</td><td>D405</td><td>SF20LC30 20A/300V</td><td>90.6°C</td><td>97.8°C</td></tr> <tr><td>16</td><td>D409</td><td>SF20LC30 20A/300V</td><td>93.0°C</td><td>100.4°C</td></tr> <tr><td>17</td><td>C403</td><td>680u/250V 105°C 25*50 MXR</td><td>73.8°C</td><td>80.8°C</td></tr> <tr><td>18</td><td>L13</td><td>TR-COIL</td><td>104.4°C</td><td>111.4°C</td></tr> <tr><td>19</td><td>L1</td><td>TR-COIL</td><td>79.9°C</td><td>86.8°C</td></tr> <tr><td>20</td><td>C7</td><td>C/MPE 156/250V 10,-5% P=41.5 MEK</td><td>76.9°C</td><td>83.3°C</td></tr> <tr><td>21</td><td>Q70</td><td>IGBT IRGP50B60PD1pbF 50A/600V TO247</td><td>81.2°C</td><td>88.3°C</td></tr> <tr><td>22</td><td>Q71</td><td>IGBT IRGP50B60PD1pbF 50A/600V TO247</td><td>83.4°C</td><td>90.8°C</td></tr> <tr><td>23</td><td>RTH2</td><td>10KΩ 1% NA1033F12D5</td><td>73.6°C</td><td>80.5°C</td></tr> <tr><td>24</td><td>C320</td><td>10u/50V UL10Kh 5*11 YXM</td><td>82.7°C</td><td>89.5°C</td></tr> <tr><td>25</td><td>U310</td><td>DRIVER IC MCP1403-E/SN(Tap.)</td><td>93.9°C</td><td>100.8°C</td></tr> <tr><td>26</td><td>T100 COIL</td><td>TF1969-R4</td><td>73.6°C</td><td>80.2°C</td></tr> <tr><td>27</td><td>Q200</td><td>STD17NF03L-1 17A/30V</td><td>67.0°C</td><td>74.0°C</td></tr> <tr><td>28</td><td>D110</td><td>2A/200V FR203</td><td>61.6°C</td><td>67.7°C</td></tr> <tr><td>29</td><td>U100</td><td>PWM TL3845P</td><td>75.7°C</td><td>83.9°C</td></tr> <tr><td>30</td><td>Q100</td><td>STP75NF75 80A/75V</td><td>77.3°C</td><td>84.7°C</td></tr> <tr><td>31</td><td>D125</td><td>HER203 2A/200V</td><td>71.2°C</td><td>78.4°C</td></tr> <tr><td>32</td><td>D200</td><td>MBR20H100CT 20A/100V</td><td>71.2°C</td><td>78.2°C</td></tr> <tr><td>33</td><td>Q601</td><td>STP75NF75 80A/75V</td><td>53.1°C</td><td>59.9°C</td></tr> <tr><td>34</td><td>RG602</td><td>PS7805F-TB3T 1.0A/5V</td><td>54.0°C</td><td>60.8°C</td></tr> <tr><td>35</td><td>RG601</td><td>LM317T-DG 1.5A</td><td>53.4°C</td><td>59.9°C</td></tr> <tr><td>36</td><td>T603 COIL</td><td>TF2169-R1</td><td>57.5°C</td><td>64.8°C</td></tr> <tr><td>37</td><td>U601</td><td>PWM TL3845D-8</td><td>63.9°C</td><td>71.3°C</td></tr> <tr><td>38</td><td>D601</td><td>SFRD US1D 1A/200V</td><td>55.7°C</td><td>63.0°C</td></tr> <tr><td>39</td><td>ZD600</td><td>ZD 0.5W 20V 5% MMSZ5250B</td><td>57.7°C</td><td>65.1°C</td></tr> <tr><td>40</td><td>U700</td><td>PWM ML4800CP</td><td>40.3°C</td><td>46.2°C</td></tr> <tr><td>41</td><td>Q700</td><td>FET IRFP460A 20A/500V</td><td>39.3°C</td><td>44.4°C</td></tr> <tr><td>42</td><td>Q701</td><td>FET 2SK3878 9A/900V</td><td>39.7°C</td><td>44.9°C</td></tr> <tr><td>43</td><td>Q850</td><td>STP75NF75 80A/75V</td><td>32.9°C</td><td>39.0°C</td></tr> </tbody> </table>		NO	Position	P/N	ROOM AMBIENT Ta= 32.9°C	HIGH AMBIENT Ta= 35.5 °C	6	C333	2200u/16V L10Kh 105°C YXG	65.8°C	71.3°C	7	L330	TF1966-R1	75.4°C	84.7°C	8	C337	755/250V 5% P=32.5 MPE	71.8°C	76.8°C	9	T330 COIL	TF2007-R2	91.0°C	97.9°C	10	T330 CORE	TF2007-R2	77.3°C	84.2°C	11	Q337	FET IXT160N075T 160A/75V TO220	98.9°C	107.4°C	12	Q333	FET IXT160N075T 160A/75V TO220	83.8°C	92.4°C	13	Q350	FET IXT160N075T 160A/75V TO220	75.7°C	84.1°C	14	D330	HER203 2A/200V	90.3°C	98.6°C	15	D405	SF20LC30 20A/300V	90.6°C	97.8°C	16	D409	SF20LC30 20A/300V	93.0°C	100.4°C	17	C403	680u/250V 105°C 25*50 MXR	73.8°C	80.8°C	18	L13	TR-COIL	104.4°C	111.4°C	19	L1	TR-COIL	79.9°C	86.8°C	20	C7	C/MPE 156/250V 10,-5% P=41.5 MEK	76.9°C	83.3°C	21	Q70	IGBT IRGP50B60PD1pbF 50A/600V TO247	81.2°C	88.3°C	22	Q71	IGBT IRGP50B60PD1pbF 50A/600V TO247	83.4°C	90.8°C	23	RTH2	10KΩ 1% NA1033F12D5	73.6°C	80.5°C	24	C320	10u/50V UL10Kh 5*11 YXM	82.7°C	89.5°C	25	U310	DRIVER IC MCP1403-E/SN(Tap.)	93.9°C	100.8°C	26	T100 COIL	TF1969-R4	73.6°C	80.2°C	27	Q200	STD17NF03L-1 17A/30V	67.0°C	74.0°C	28	D110	2A/200V FR203	61.6°C	67.7°C	29	U100	PWM TL3845P	75.7°C	83.9°C	30	Q100	STP75NF75 80A/75V	77.3°C	84.7°C	31	D125	HER203 2A/200V	71.2°C	78.4°C	32	D200	MBR20H100CT 20A/100V	71.2°C	78.2°C	33	Q601	STP75NF75 80A/75V	53.1°C	59.9°C	34	RG602	PS7805F-TB3T 1.0A/5V	54.0°C	60.8°C	35	RG601	LM317T-DG 1.5A	53.4°C	59.9°C	36	T603 COIL	TF2169-R1	57.5°C	64.8°C	37	U601	PWM TL3845D-8	63.9°C	71.3°C	38	D601	SFRD US1D 1A/200V	55.7°C	63.0°C	39	ZD600	ZD 0.5W 20V 5% MMSZ5250B	57.7°C	65.1°C	40	U700	PWM ML4800CP	40.3°C	46.2°C	41	Q700	FET IRFP460A 20A/500V	39.3°C	44.4°C	42	Q701	FET 2SK3878 9A/900V	39.7°C	44.9°C	43	Q850	STP75NF75 80A/75V	32.9°C	39.0°C	
		NO	Position	P/N		ROOM AMBIENT Ta= 32.9°C	HIGH AMBIENT Ta= 35.5 °C																																																																																																																																																																																																		
		6	C333	2200u/16V L10Kh 105°C YXG		65.8°C	71.3°C																																																																																																																																																																																																		
		7	L330	TF1966-R1		75.4°C	84.7°C																																																																																																																																																																																																		
		8	C337	755/250V 5% P=32.5 MPE		71.8°C	76.8°C																																																																																																																																																																																																		
		9	T330 COIL	TF2007-R2		91.0°C	97.9°C																																																																																																																																																																																																		
		10	T330 CORE	TF2007-R2		77.3°C	84.2°C																																																																																																																																																																																																		
		11	Q337	FET IXT160N075T 160A/75V TO220		98.9°C	107.4°C																																																																																																																																																																																																		
		12	Q333	FET IXT160N075T 160A/75V TO220		83.8°C	92.4°C																																																																																																																																																																																																		
		13	Q350	FET IXT160N075T 160A/75V TO220		75.7°C	84.1°C																																																																																																																																																																																																		
		14	D330	HER203 2A/200V		90.3°C	98.6°C																																																																																																																																																																																																		
		15	D405	SF20LC30 20A/300V		90.6°C	97.8°C																																																																																																																																																																																																		
		16	D409	SF20LC30 20A/300V		93.0°C	100.4°C																																																																																																																																																																																																		
		17	C403	680u/250V 105°C 25*50 MXR		73.8°C	80.8°C																																																																																																																																																																																																		
		18	L13	TR-COIL		104.4°C	111.4°C																																																																																																																																																																																																		
		19	L1	TR-COIL		79.9°C	86.8°C																																																																																																																																																																																																		
		20	C7	C/MPE 156/250V 10,-5% P=41.5 MEK		76.9°C	83.3°C																																																																																																																																																																																																		
		21	Q70	IGBT IRGP50B60PD1pbF 50A/600V TO247		81.2°C	88.3°C																																																																																																																																																																																																		
		22	Q71	IGBT IRGP50B60PD1pbF 50A/600V TO247		83.4°C	90.8°C																																																																																																																																																																																																		
		23	RTH2	10KΩ 1% NA1033F12D5		73.6°C	80.5°C																																																																																																																																																																																																		
		24	C320	10u/50V UL10Kh 5*11 YXM		82.7°C	89.5°C																																																																																																																																																																																																		
		25	U310	DRIVER IC MCP1403-E/SN(Tap.)		93.9°C	100.8°C																																																																																																																																																																																																		
		26	T100 COIL	TF1969-R4		73.6°C	80.2°C																																																																																																																																																																																																		
		27	Q200	STD17NF03L-1 17A/30V		67.0°C	74.0°C																																																																																																																																																																																																		
		28	D110	2A/200V FR203		61.6°C	67.7°C																																																																																																																																																																																																		
		29	U100	PWM TL3845P		75.7°C	83.9°C																																																																																																																																																																																																		
		30	Q100	STP75NF75 80A/75V		77.3°C	84.7°C																																																																																																																																																																																																		
		31	D125	HER203 2A/200V		71.2°C	78.4°C																																																																																																																																																																																																		
		32	D200	MBR20H100CT 20A/100V		71.2°C	78.2°C																																																																																																																																																																																																		
		33	Q601	STP75NF75 80A/75V		53.1°C	59.9°C																																																																																																																																																																																																		
		34	RG602	PS7805F-TB3T 1.0A/5V		54.0°C	60.8°C																																																																																																																																																																																																		
		35	RG601	LM317T-DG 1.5A		53.4°C	59.9°C																																																																																																																																																																																																		
		36	T603 COIL	TF2169-R1		57.5°C	64.8°C																																																																																																																																																																																																		
		37	U601	PWM TL3845D-8		63.9°C	71.3°C																																																																																																																																																																																																		
		38	D601	SFRD US1D 1A/200V		55.7°C	63.0°C																																																																																																																																																																																																		
		39	ZD600	ZD 0.5W 20V 5% MMSZ5250B		57.7°C	65.1°C																																																																																																																																																																																																		
		40	U700	PWM ML4800CP		40.3°C	46.2°C																																																																																																																																																																																																		
		41	Q700	FET IRFP460A 20A/500V		39.3°C	44.4°C																																																																																																																																																																																																		
		42	Q701	FET 2SK3878 9A/900V		39.7°C	44.9°C																																																																																																																																																																																																		
43	Q850	STP75NF75 80A/75V	32.9°C	39.0°C																																																																																																																																																																																																					
2	LOW TEMPERATURE TURN ON TEST	TURN ON AFTER 2 HOUR	I/P : 12VDC O/P : 100 % LOAD Ta= 0 °C	TEST : OK	P																																																																																																																																																																																																				

3	HIGH HUMIDITY HIGH TEMPERATURE HIGH VOLTAGE TURN ON TEST	AFTER 12 HOURS IN CHAMBER ON CONTROL 40 °C NO DAMAGE	I/P : 14.5VDC O/P : FULL LOAD Ta= 40 °C HUMIDITY= 95 %R.H	TEST : OK	P
4	STORAGE TEMPERATURE TEST	1. Thermal shock Temperature : -45°C~ +90°C 2. Temperature change rate : 25°C / MIN 3. Dwell time low and high temperature : 30 MIN/EACH 4. Total test cycle : 5 CYCLE 5. Input/Output condition : STATIC		TEST : OK	P
5	THERMAL SHOCK TEST	1. Thermal shock Temperature : -5°C~ +45°C 2. Temperature change rate : 25°C / MIN 3. Dwell time low and high temperature : 30 MIN/EACH 4. Total test cycle : 10 CYCLE 5. Input/Output condition : 12VDC/Full Load		TEST : OK	P
6	VIBRATION TEST	1 Carton & 1 Set (1) Waveform : Sine Wave (2) Frequency : 10~500Hz (3) Sweep Time : 10min/sweep cycle (4) Acceleration : 3G (5) Test Time : 60min in each axis (X.Y.Z) (6) Ta : 25°C		TEST : OK	P
7	CAPACITOR LIFE CYCLE	TN-3000-212 : SUPPOSE C 333 IS THE MOST CRITICAL COMPONENT (1) I/P : 12VDC O/P : FULL LOAD Ta= 25 °C LIFE TIME (2) I/P : 12VDC O/P : FULL LOAD Ta= 40 °C LIFE TIME		(1) 247044 HRS (2) 71460 HRS	P

SAFETY TEST

NO	TEST ITEM	SPECICATION	TEST CONDITION	RESULT	VERDICT
1	WITHSTAND VOLTAGE	BAT I/P-AC I/P: 3 KVAC/min BAT I/P-ACO/P: 3 KVAC/min AC O/P-FG: 1.5 KVAC/min	BAT I/P-AC I/P: 3.6 KVAC/min BAT I/P-ACO/P: 3.6 KVAC/min AC O/P-FG: 1.8 KVAC/min Ta:25°C	BAT I/P-AC I/P: 9.24mA BAT I/P-ACO/P: 9.24mA AC O/P-FG: 5.62mA NO DAMAGE	P
2	ISOLATION RESISTANCE	BAT I/P-AC I/P:500VDC>100MΩ BAT I/P- AC O/P:500VDC>100MΩ AC O/P-FG:500VDC>100MΩ	BAT I/P-AC I/P: 500 VDC BAT I/P-ACO/P: 500 VDC AC O/P-FG: 500 VDC Ta:25°C	BAT I/P-AC I/P: 4.4GΩ BAT I/P-AC O/P: 4.4GΩ AC O/P-FG: 10GΩ NO DAMAGE	P
3	GROUNDING CONTINUITY	EN 60950 FG(PE) TO CHASSIS OR TRACE < 100 mΩ	40 A / 2min Ta:25°C	11mΩ	P

E.M.C TEST

NO	TEST ITEM	SPECICATION	TEST CONDITION	RESULT	VERDICT
1	CONDUCTION	EN55022 CLASS A	I/P: 24 VDC O/P: FULL/50% LOAD Ta:25°C	CRITERIA A	P
2	RADIATION	EN55022 CLASS A	I/P: 24 VDC O/P: : FULL/50% LOAD Ta:25°C	CRITERIA A	P
3	E.S.D	EN61000-4-2 LIGHT INDUSTRY AIR:8KV / Contact:4KV	I/P: 24VDC O/P: FULL LOAD Ta:25°C	CRITERIA A	P
4	E.F.T	EN61000-4-4 LIGHT INDUSTRY INPUT: 1KV	I/P: 24 VDC O/P: FULL LOAD Ta:25°C	CRITERIA A	P
5	SURGE	IEC61000-4-5 LIGHT INDUSTRY L-N :1KV L,N-PE:2KV	I/P: 24 VDC O/P: FULL LOAD Ta:25°C	CRITERIA A	P

DATE	SAMPLE	TEST RESULT	TESTER	APPROVAL
2010/4/2	RD SAMPLE	PASS	SANFORD SU	VINCENT TSENG
2010/8/4	PRODUCT SAMPLE	PASS	SANFORD SU	VINCENT TSENG

2003/24/24 A50-F023